



TORQUI

FITTING IN

WHERE OTHERS DON'T

TX SQUARE DRIVE RATCHET LINK

SDL

TX SERIES SQUARE DRIVE LINK THE DRIVING TORQUE



TECHNICAL DATA SDL

MIN TORQUE (ft-lbs)	293
MAX TORQUE (ft-lbs)	2934
MIN TORQUE (nm)	397.3
MAX TORQUE (nm)	3978
OUTPUT ACCURACY	+/-3%
REPEATABILITY	100%
DUTY CYCLE	100%
CYLINDER WEIGHT (lbs)	6.0
CYLINDER WEIGHT (kgs)	2.7
LINK WEIGHT (lbs)	9
LINK WEIGHT (kgs)	4.1

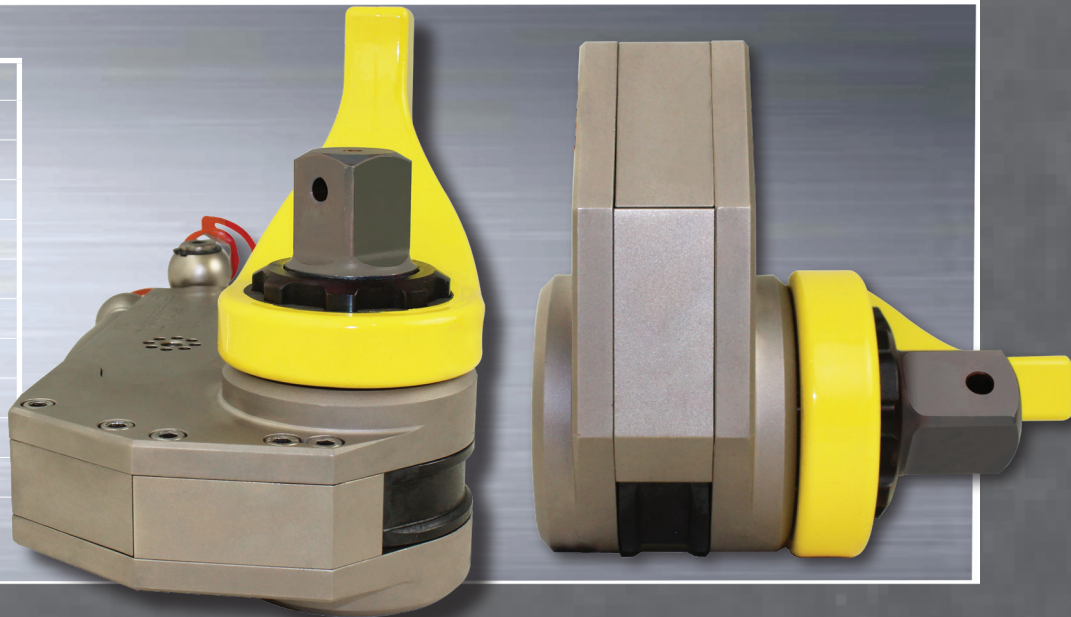

DIMENSIONAL DATA SDL

POWER ENGINEERED

Length (in)	Length (mm)	Height (in)	Height (mm)	Width 1 (in)	Width 1 (mm)	Width 2 (in)	Width 2 (mm)	Radius (in)	Radius (mm)	Square Drive	Reaction (Min)	Reaction (Max)
8.20	208.3	4.67	118.6	6.67	169.4	2.66	67.6	1.43	36.32	1"	3.41	5.16

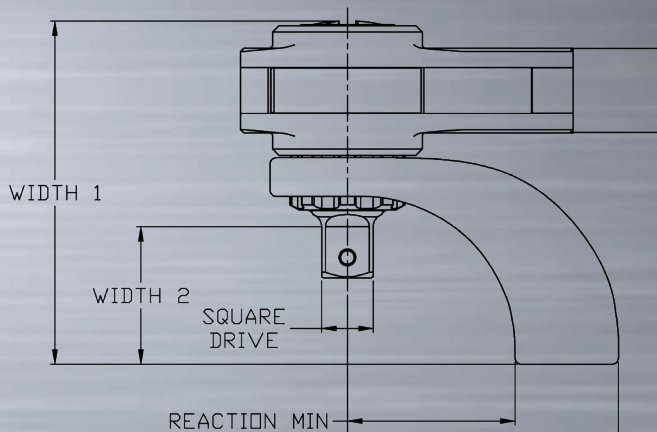
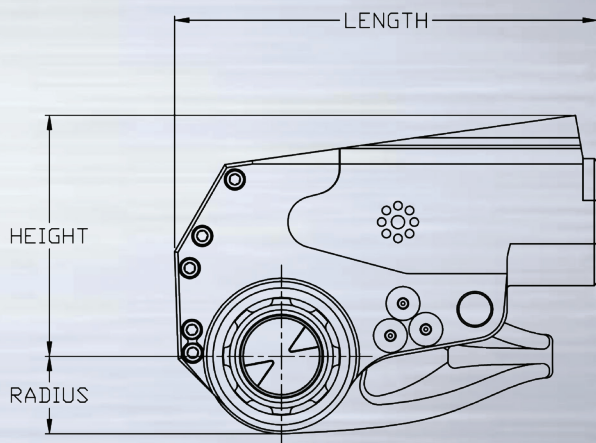

WWW.TORCUP.COM

TorcUP Inc. 1025 Conroy Place Easton, PA. 18040 USA 1-888-TorcUP-1 +1 610-250-5800

www.torcup.com sales@torcup.com

TorcUP products are subject to continual development and TorcUP reserves the right to make changes to the specifications and design of their products without prior notice. All rights are reserved. Reproduction in whole or in part without permission of TorcUP Inc. is prohibited.